

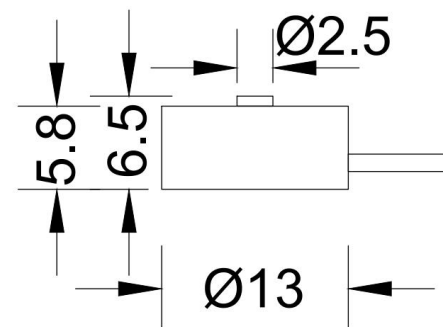

### 主要特点/Features

- 压式
- 合金钢/不锈钢材质
- 高度低形变小
- 安装简便、尺寸小
- 适用于装配力、夹紧力、狭小空间的力检测等

### 尺寸 Dimensions in mm:



### 接线/Wiring diagram:

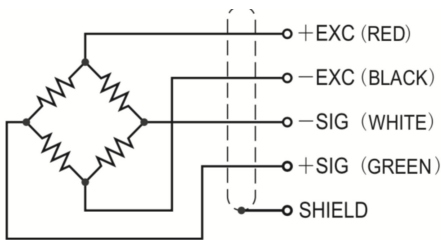

### 技术指标/Specifications

额定容量/Rated Capacity	5 ~ 100kg
精度等级/Accuracy level	0.5%FS
综合误差/Comprehensive error	±0.5%FS
输出灵敏度/Rated output	1 ~ 2.0 ±0.2mV/V
零点平衡/Zero balance	±1.5%FS
蠕变 (30 分钟) Creep (30 minutes)	±0.5%FS
补偿温度范围/Comp.Temp.	-10°C~40°C
工作温度范围/Working Temp. Range	-20°C~60°C
零点温度影响/Temp. Effect on zero	±0.3%FS/10°C
灵敏度温度影响/Temp. Effect on output	±0.3%FS/10°C
输入阻抗/Input impedance	350 ±10Ω
输出阻抗/Output impedance	300 ±3Ω
绝缘阻抗/Insulation impedance	≥5000MΩ
推荐激励电压/Recommended excitation	9~12VDC
安全过载/Safe overload	120%FS
极限过载/Ultimate Overload	150%FS
材质/Material	合金钢/Alloy steel construction
电缆线规格/Cable specification	1.5mm, 四芯屏蔽电缆线/4-wire shielded cable
防护等级/Protection level	IP65
认证/Authentication	CE、RoHS
电子数据/TEDS	可选/Optional